

ISSUE 560 BULLETIN



PILE FOUNDATIONS

May 2013

■ This bulletin explains the requirements of NZS 3604:2011 *Timber-framed buildings* for pile foundation systems.

■ NZS 3604 identifies the types of piles as ordinary piles, driven timber piles, driven timber cantilevered piles, braced pile systems and anchor piles.

■ This bulletin updates and replaces Bulletin 399 *Timber pile foundations*.

1.0 SCOPE

1.0.1 The New Zealand Building Code compliance document to clause B1 *Structure*, B1/AS1, cites NZS 3604:2011 *Timber-framed buildings* as an Acceptable Solution for foundations for timber-framed buildings founded on good ground.

1.0.2 This bulletin should be read in conjunction with NZS 3604. It describes and explains the functions and requirements of timber pile systems contained in that document.

1.0.3 This bulletin updates and replaces Bulletin 399 *Timber pile foundations*.

2.0 FOUNDATIONS AND NZS 3604

2.0.1 The function of a foundation is to provide resistance to the vertical and horizontal loads acting on a building by transferring those forces to the ground.

2.0.2 Vertical loads acting on a building are generated by:

- its weight
- wind uplift
- earthquake vertical movement
- internal live and superimposed floor loads (the weight of people, furniture and so on).

2.0.3 Horizontal loads acting on a building are generated by:

- the action of the wind on the external walls, subfloor cladding and the roof
- earthquake forces moving the ground horizontally beneath the building.

2.0.4 Section 6 of NZS 3604 sets out methods to be used to:

- assess the vertical and horizontal forces acting on the building for timber-framed buildings with floor loadings not exceeding 3 kPa
- design a structure that will resist these forces without the need for specific engineering design.

2.0.5 The methods used in NZS 3604 take into consideration all those factors that influence the structure such as the:

- use to which the building will be put – maximum floor load of 3 kPa
- configuration of the building
- condition of the ground on which the building rests
- combined vertical dead (building weight) and live (weight of people and furniture) loads
- wind uplift
- snow loads
- horizontal wind and earthquake loads.

3.0 FOUNDATION SYSTEMS

3.0.1 All the loads acting on a building (vertical wind uplift and gravity loads and horizontal wind and earthquake loads) are transferred to the ground by one of the following (Figures 1 and 2):

- Piles installed to specifically resist horizontal wind and earthquake loads – braced piles, driven timber cantilevered piles or anchor piles.
- A foundation system that uses both concrete or concrete masonry foundation walls together with piles specifically installed to resist horizontal wind and earthquake loads.
- A concrete slab on ground that transfers the loads directly to the ground – refer BRANZ Bulletin 541 *Concrete floor slabs*.

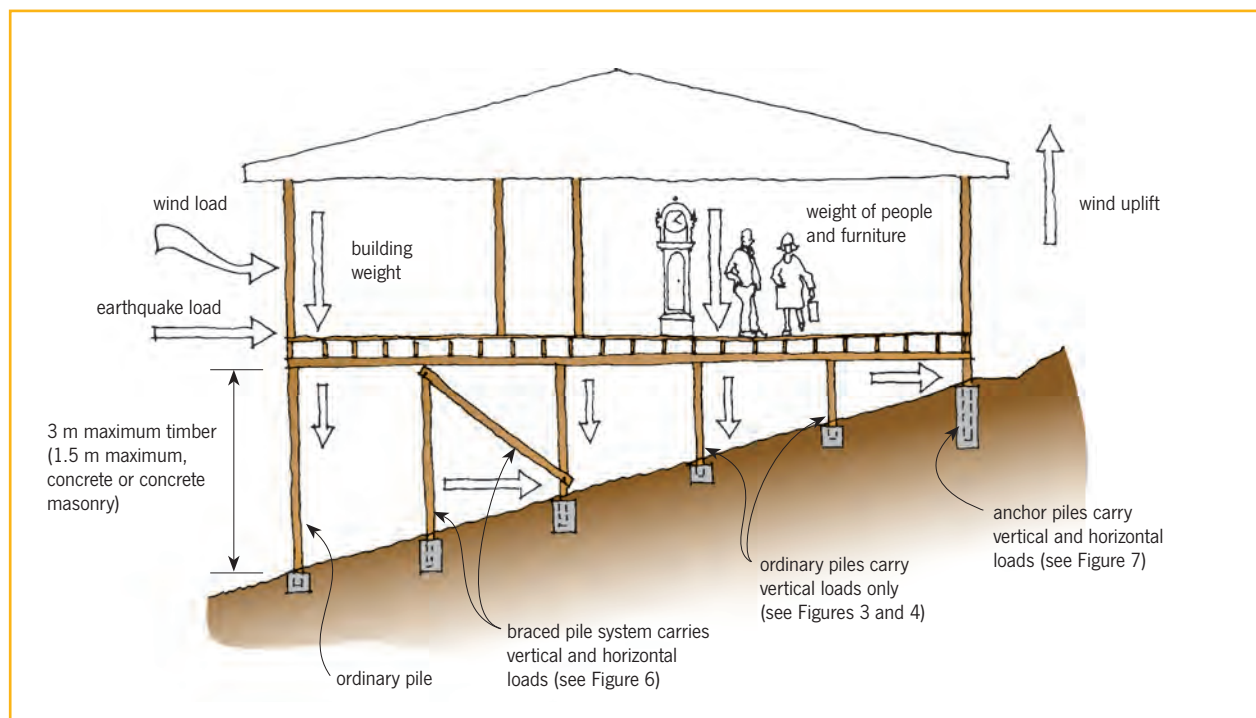

Figure 1. A piling system comprising ordinary piles, braced piles and anchor piles.

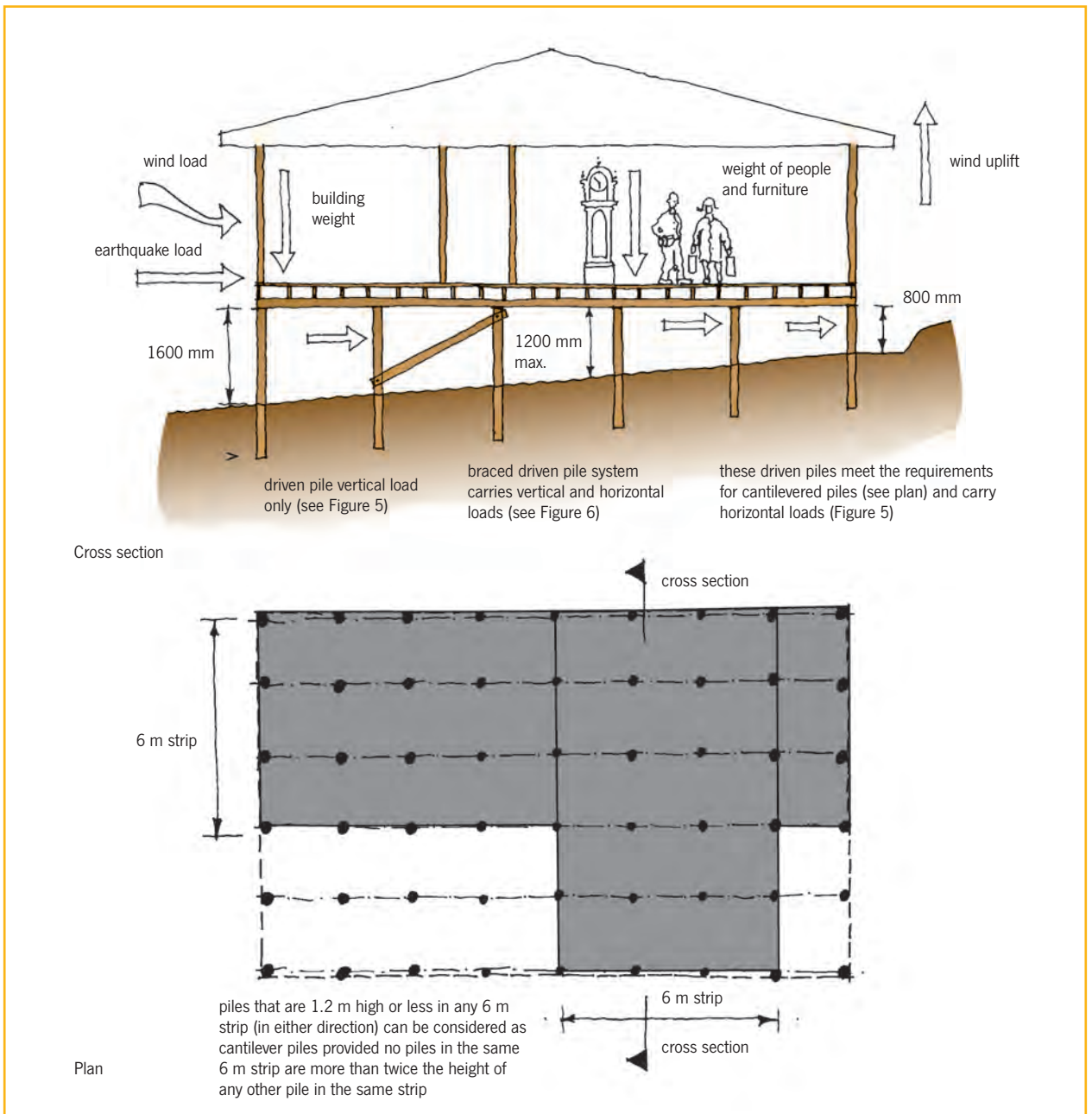

Figure 2. A piling system comprising driven piles, cantilever piles and braced piles.

- Concrete or concrete masonry foundation walls (see NZS 3604 section 6.11) that resist the horizontal wind and earthquake loads with internal piles to transfer the vertical loads to the ground.

3.0.2 NZS 3604 identifies the types of piles as:

- ordinary piles
- driven timber piles
- driven timber cantilevered piles
- braced pile systems
- anchor piles.

3.0.3 Other design parameters that need to be considered for pile foundations include:

- the design floor loads – section 14 of NZS 3604 gives the requirements for 3 kPa floor loads
- required clearances from the top of a bank or slope (NZS 3604 section 3)
- the need to provide subfloor support to loadbearing walls above (NZS 3604 Figure 6.1)

- the calculation of subfloor bracing and location of bracing lines.

4.0 PILE FOUNDATIONS

4.1 TIMBER PILES GENERALLY

4.1.1 Timber piles are round or square sections of treated timber that are either:

- set on a concrete footing in a hole dug in the ground (ordinary piles)
- fully encased in concrete (braced or anchor piles)
- mechanically driven into the ground.

4.1.2 Timber piles must comply with NZS 3605:2001 *Timber piles and poles for use in building* and may be:

- 140 mm minimum diameter natural round timber
- 125 x 125 mm square sawn timber.

4.1.3 Anchor piles must be marked as required in NZS 3605 with an 'A'.

4.1.4 Timber piles must be treated against decay to hazard class H5 of NZS 3640:2003 *Chemical preservation of round and sawn timber*. If a timber pile is cut, the surface of the cut must be retreated with preservative. No cuts in the treated piles must occur closer than 300 mm to the finished ground level. This can be reduced to 150 mm if a damp-proof course (DPC) is placed between the pile and framing timbers. A cut end must not be placed in the ground, and exposed cut ends must be site treated with a timber preservative.

4.1.5 All preservative-treated piles must be branded to the requirements of NZS 3640.

4.1.6 No notching or boring of piles within 150 mm of the ground is permitted by NZS 3604.

4.1.7 Timber piles may support a bearer or a jack stud.

4.2 CONCRETE PILES GENERALLY

4.2.1 Concrete piles, while not commonly used, can be a precast concrete (round, square or tapered) or concrete masonry (square) unit that is:

- set on a concrete footing in a hole dug in the ground (ordinary piles)
- fully encased in concrete (braced or anchor piles).

4.2.2 Concrete or concrete masonry piles shall be reinforced with 1 x D10 bar located centrally for concrete piles over 750 mm long and concrete masonry piles over 500 mm long (NZS 3604 clause 6.4.4).

4.2.3 Concrete piles shall be ordinary grade concrete with a minimum compressive strength of 17.5 MPa in exposure zone B, 20 MPa in exposure zone C and 25 MPa in exposure zone D.

4.2.4 Minimum pile dimensions are:

- 200 mm square or 200 mm diameter for straight-sided precast concrete
- 150 mm square or 150 mm diameter at the top and 200 mm square or 200 mm diameter at the bottom for tapered precast piles
- 190 mm square for concrete masonry piles constructed in situ.

4.2.5 Concrete or concrete masonry piles may support a bearer or a jack stud.

4.3 PILE FOOTINGS AND CONCRETE ENCASEMENT

4.3.1 Concrete pile footings with a 100 mm minimum thickness under the bottom of the pile are required for all ordinary, braced and anchor piles.

4.3.2 Ordinary piles not cast with the footing are required to be temporarily braced or have the pile embedded sufficiently into the footing to provide

stability during construction. For ordinary timber piles, the minimum footing depth is 200 mm, with the timber embedded 100 mm into the concrete.

4.3.3 Braced and anchor piles must also be fully encased in concrete.

4.3.4 Minimum pile footing sizes are given in NZS 3506 Table 6.1 and are based on the pile spacing and the gravity load a pile will be carrying. No footing to an anchor or braced pile is permitted to be less than 350 x 350 mm if square or 400 mm in diameter if round.

4.3.5 Concrete for pile footings to all piles must be ordinary grade concrete of 17.5 MPa minimum strength in accordance with NZS 3109:1997 *Concrete construction*.

4.4 ORDINARY PILES

4.4.1 Ordinary piles transfer vertical loads (the weight of the building and contents) to the ground but make no contribution to resisting horizontal (wind and earthquake) loads. If the horizontal loads are to be resisted by piles (and not by concrete foundation walls), ordinary piles must be supplemented by braced pile systems and/or anchor piles (Figure 1). (Driven timber cantilever piles may also be used for bracing.)

4.4.2 The basic requirements and configuration for ordinary piles are shown in Figures 3 and 4.

4.5 DRIVEN TIMBER PILES

4.5.1 Driven timber piles are placed by a mechanical impact driver that forces them into the ground until sufficient resistance to driving is obtained and the minimum depth has been reached (Figure 5 and refer NZS 3604 clause 6.6).

4.5.2 Driven timber piles may be used as ordinary piles, cantilevered piles or braced piles. They must be driven with the small end into the ground.

4.5.3 Driven timber piles used as ordinary piles to transfer vertical loads to the ground make no contribution to resisting horizontal loads unless they can be considered as cantilevered piles (see section 4.6 below). If the horizontal loads are to be resisted by these piles (and not by concrete foundation walls), driven timber piles must be supplemented by driven braced pile systems and/or other driven cantilevered piles (Figure 2).

4.5.4 Driven timber piles are often used in situations where there is insufficient height for braced piles and/or the ground at the surface has inadequate bearing capacity and the piles can be driven to a depth where better bearing can be obtained. When only cantilevered piles are used for bracing under these circumstances, it is possible that, because of soft soil near the surface, they may eventually allow excessive horizontal movement. In this situation, specific design should be considered.

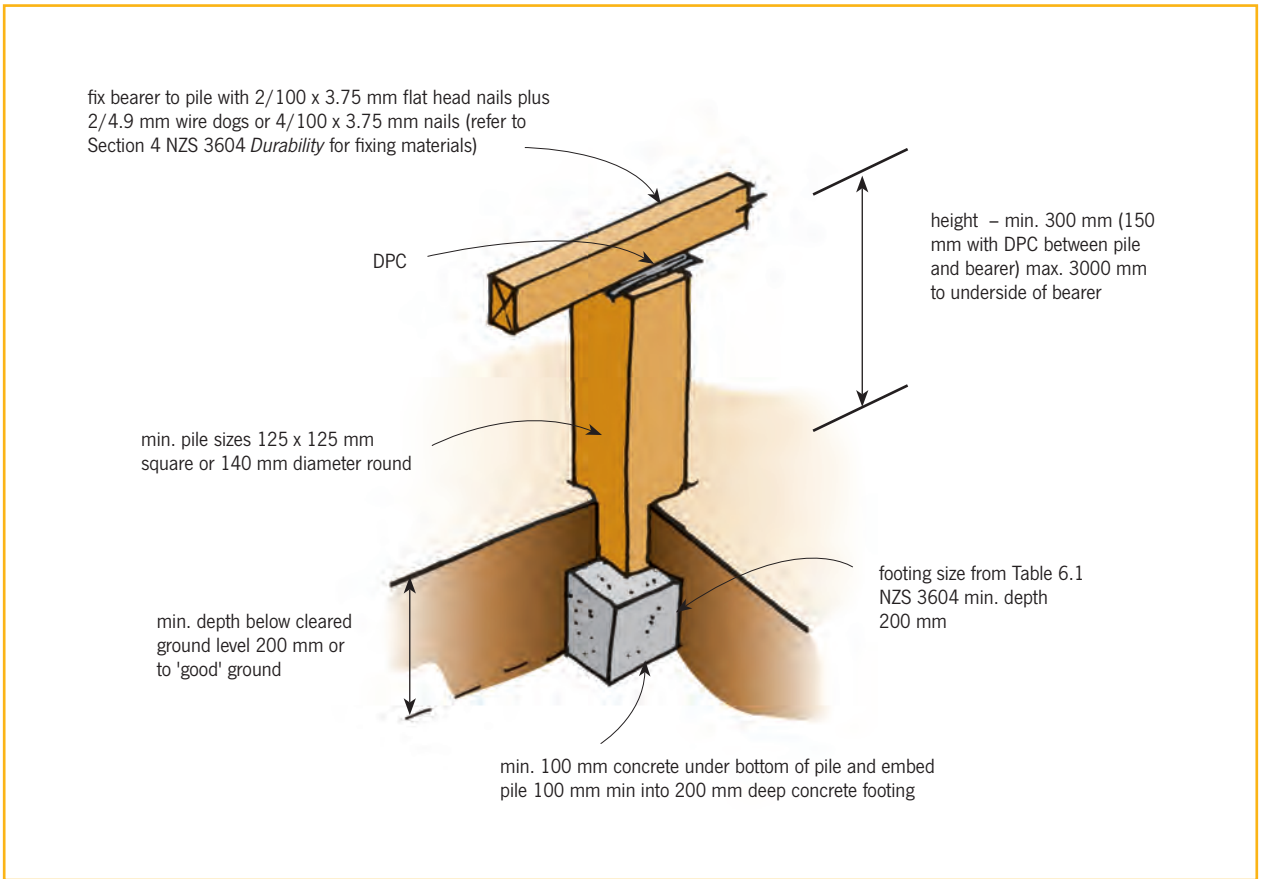

Figure 3. Ordinary timber piles.

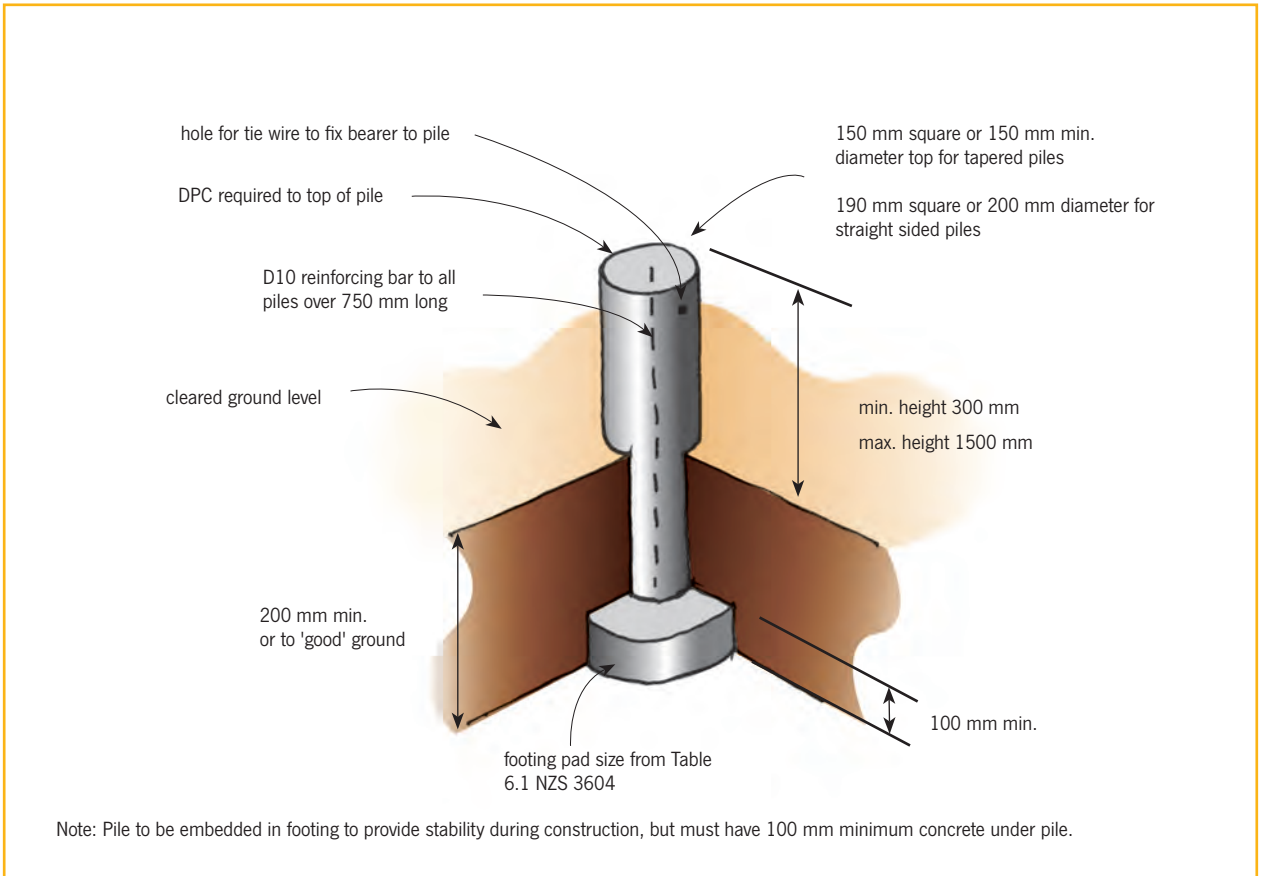

Figure 4. Ordinary concrete piles.

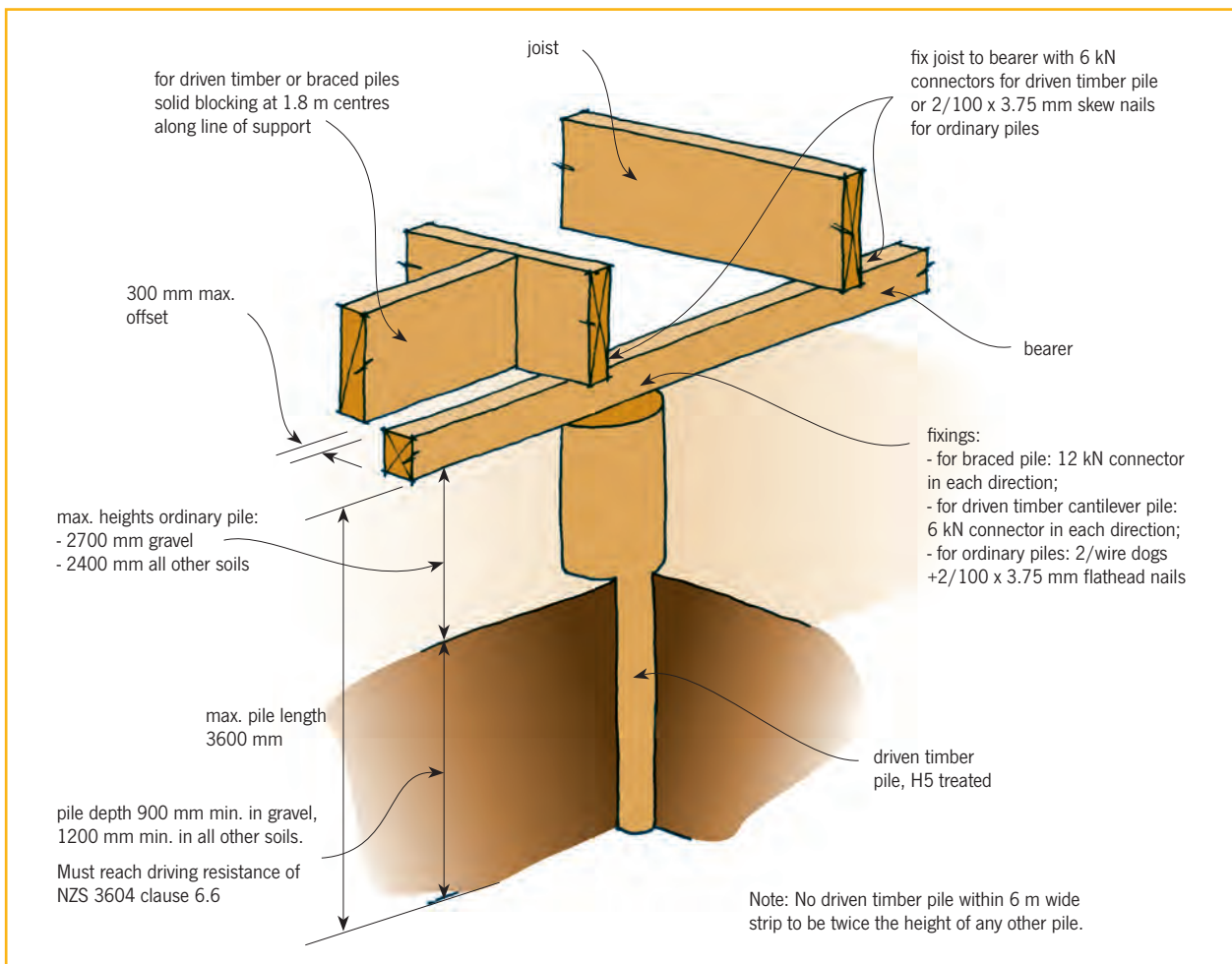

Figure 5. Driven timber piles.

4.5.5 The basic requirements and configuration for driven timber piles are shown in Figure 5.

4.5.6 The spacing of driven timber piles is given by NZS 3604 Table 6.2 and is based on the driving resistance of the piles with the requirement that the spacing does not exceed the permitted bearer span.

4.5.7 Where a pile has been driven to the height required for the bearer but has not achieved the required driving resistance, additional piles shall be driven on each side of it to achieve the required driving resistance.

4.5.8 NZS 3604 requires the driving of a test pile (before delivery of all the piles) to ensure adequate driving resistance can be obtained.

4.6 DRIVEN TIMBER CANTILEVERED PILES

4.6.1 Driven cantilevered piles are those cantilevered piles (Figure 2) where:

- the pile top is not more than 1.2 m above cleared ground level
- no cantilevered pile within a 6 m wide strip is more than twice the height of any other pile (this restriction applies in both directions).

4.6.2 These requirements mean that the number of driven piles that can be used as cantilevered piles may be limited by the slope of the ground under a building.

4.6.3 Cantilevered driven piles carry vertical loads and resist horizontal loads in both directions – each pile contributes 70 wind bracing units and 30 earthquake bracing units to the total requirement.

4.6.4 The basic requirements and configuration of driven timber cantilevered piles are shown in Figure 5.

4.7 BRACED PILE SYSTEMS

4.7.1 A braced pile system consists of two timber braced piles (with a 450 mm deep concrete encasement that matches the footing dimensions or driven piles) between which a diagonal brace is fixed. Concrete around the pile must be a minimum of 400 mm diameter or 300 x 300 mm if square. Braced piles carry vertical loads and resist horizontal loads along the line of the brace – each braced pair contributes 160 wind bracing units and 120 earthquake bracing units to the total requirement (Figures 1 and 2).

4.7.2 The diagonal brace is fixed at its lower end to a braced pile, and its upper end may be fixed to:

- the top of an adjacent braced pile, or
- a joist within 200 mm of a braced pile, or
- a bearer within 200 mm of a braced pile.

4.7.3 Braced piles may be repeated in a series with braces sloping in the same direction. Only one brace may be fixed to the top of any one braced pile, but two

braces may be fixed to the bottom of a braced pile if the braces are at right angles to each other.

4.7.4 The basic requirements and configuration of braced piles are shown in Figure 6.

4.7.5 The minimum vertical height between the top and bottom fixings of a brace is $3 \times H$ where H equals the distance from the lowest brace fixing to the cleared ground (Figure 6). Because of this minimum height requirement, braced piles cannot be used in conjunction with piles shorter than 800 mm. In this case, anchor piles must be used to obtain bracing.

4.7.6 Diagonal timber braces must:

- be 100 x 75 mm for lengths up to 3 m
- be 100 x 100 mm for lengths over 3 m but less than 5 m
- have the lower end of the brace not closer than 150 mm to the cleared ground level or more than 300 mm above the cleared ground level
- be bolted to the pile, bearer or joist with an M12 bolt or a proprietary connector with a capacity of not less than 17 kN in tension and compression
- have the bottom bolt to the brace not more than 300 mm above or less than 200 mm above cleared ground level

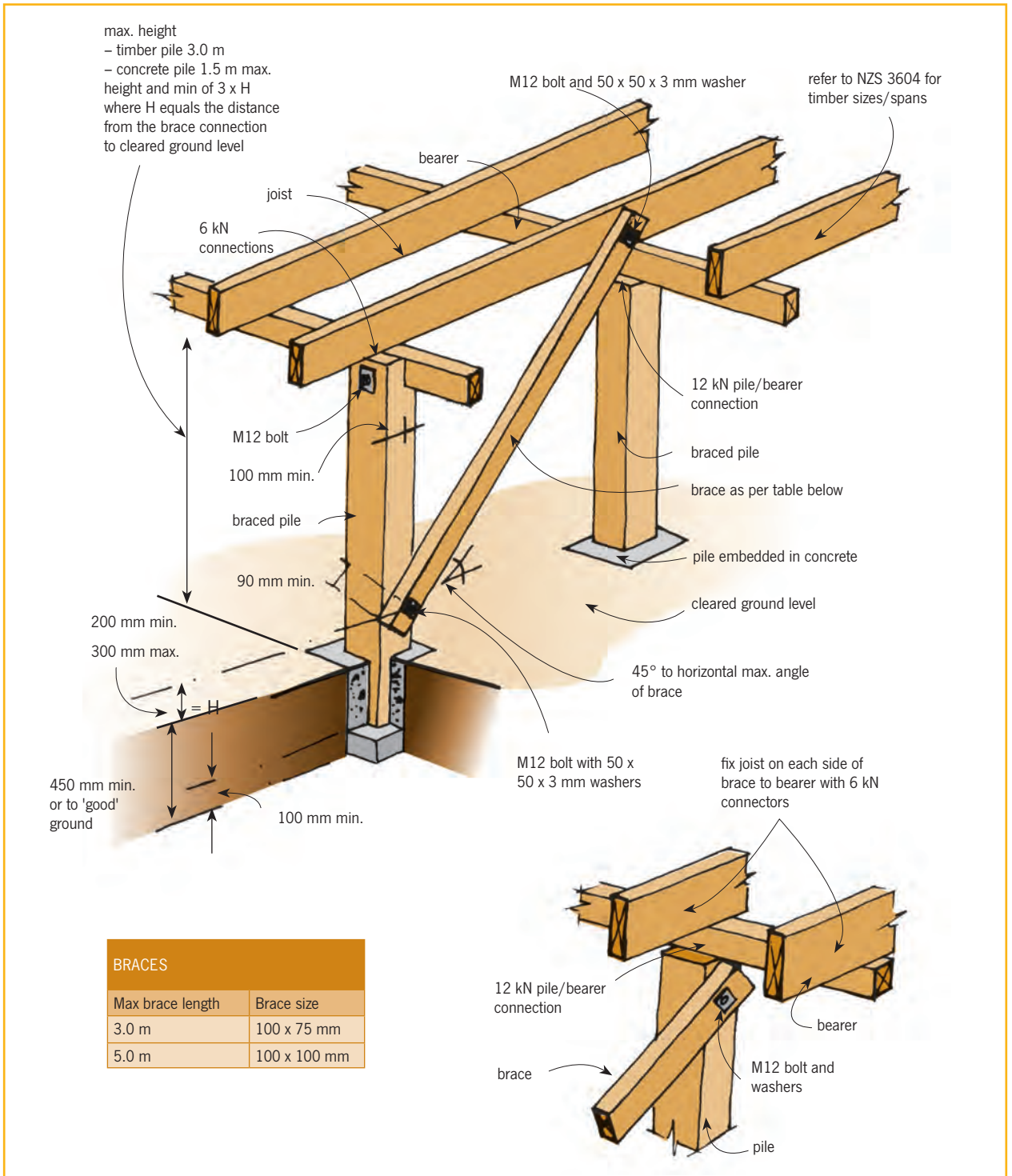

Figure 6. Braced piles.

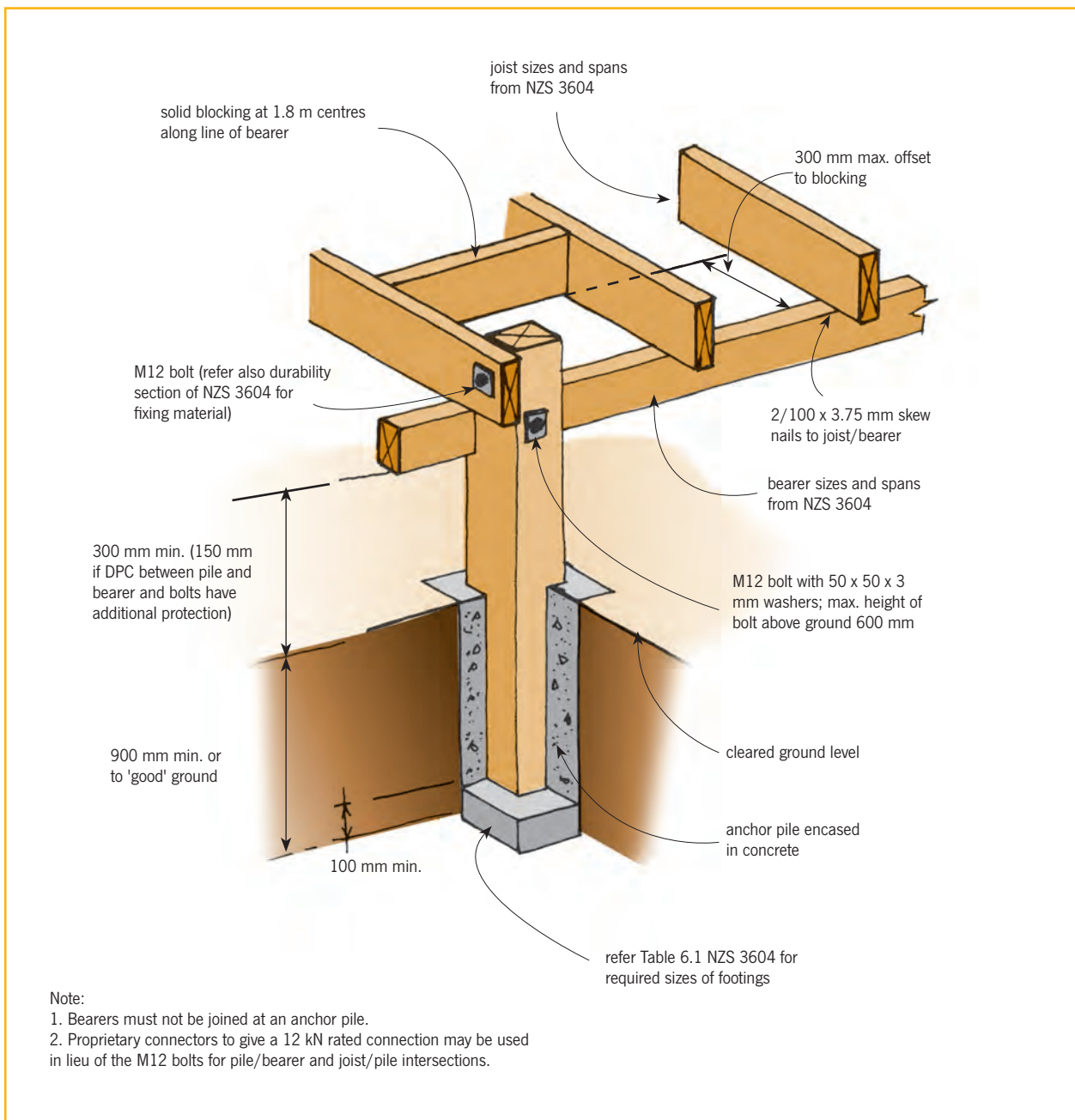

Figure 7. Anchor piles.

- have a maximum slope of 45° (10° minimum but this can reduce to 6° minimum where connected to a bearer or joist)
- have a minimum timber grade of SG8.

4.7.7 Only one brace may be connected at the top of a braced pile – two braces at right angles to each other may be connected to the base of a single braced pile.

4.7.8 Bearers must be connected to braced piles with an M12 bolt with 50 x 50 x 3 mm washer or a proprietary connector with a capacity of not less than 12 kN:

- in the horizontal direction when the brace is connected to the pile
- in the vertical direction when the brace is attached to the bearer or joist.

4.7.9 Two joists adjacent to the pile (preferably on each side) must be connected to the bearer with a 6 kN proprietary connector.

4.8 ANCHOR PILES

4.8.1 Anchor piles are short piles with deep footings designed to resist horizontal forces along and across the building – each pile contributes 160 wind bracing units and 120 earthquake bracing units to the total requirement.

4.8.2 Anchor piles must be a minimum of 900 mm deep in the ground and surrounded with concrete (Figure 7) for the full depth including the 100 mm depth of concrete under the base of the pile. Concrete around the pile must be a minimum of 400 mm

TABLE 1: SUMMARY OF PILE TYPES AND KEY INSTALLATION REQUIREMENTS

Pile type	Load resistance	Bracing units	Minimum depth in the ground	Concrete footing ⁽¹⁾	Height above ground
Ordinary timber (Figure 3)	Vertical only	None provided	200 mm	200 mm deep with 100 mm pile embedment	Min. 150 mm ⁽²⁾ Max. 3000 mm
Ordinary concrete (Figure 4)	Vertical only	None provided	200 mm	100 mm deep	Min. 150 mm ⁽²⁾ Max. 1500 mm
Driven timber ordinary (Figure 5)	Vertical only	None provided	900 mm in gravel 1200 mm in other soil until driving resistance is reached (maximum pile length of 3600 mm applies)	Not required	Min. 150 mm ⁽²⁾ Max. 2700 mm
Driven timber cantilever (Figure 5)	Vertical and horizontal	Wind 70 Earthquake 30	900 mm in gravel. 1200 mm in other soil or until driving resistance is reached	Not required	Min. 150 mm ⁽²⁾ Max. 1200 mm
Braced (Figure 6)	Vertical and horizontal	Wind 160 Earthquake 120	450 mm or as for driven piles	450 mm or driven pile	Min. 600 mm Max. 3000 mm timber, 2700 mm for driven timber or 1500 mm for concrete
Anchor (Figure 7)	Vertical and horizontal	Wind 160 Earthquake 120	900 mm	900 mm	Min. 150 mm ⁽²⁾ Max. 600 mm to highest fixing

Notes: (1) The plan size of footings is given in NZS 3604 Table 6.1.

(2) The minimum is 300 mm but this may be reduced to 150 mm if a DPC is inserted between the pile and bearer or jack stud.

diameter or 350 x 350 mm if square. Anchor piles are fixed to the bearer and floor joists with the upper fixing at a maximum of 600 mm above cleared ground to the fixing.

4.8.3 Required connections adjacent to the anchor piles are:

- pile to bearer – an M12 bolt with 50 x 50 x 3 mm square washer (or 55 mm diameter x 3 washer) or a 12 kN proprietary connector
- joist to pile (where adjacent) – an M12 bolt with 50 x 50 x 3 mm square washer (or 55 mm diameter x 3 washer)
- joist to bearer – 6 kN proprietary connector to two joists adjacent to the pile.

4.8.4 The basic requirements and configuration of anchor piles are shown in Figure 7.

5.0 SUMMARY OF PILE TYPES

5.0.1 Table 1 gives a summary of timber pile types and some of their characteristics.

6.0 FIXINGS AND DURABILITY

6.0.1 NZS 3604 Table 4.1 specifies the requirements for metal connections within pile foundation systems.

6.0.2 Stainless steel is required for

- all connections to ACQ and CuAz treated timber
- all structural fixings in exposure zone D
- connections to treated piles within 600 mm of the ground in a sheltered or exposed situation
- connections to treated piles that are more than 600 mm from the ground in an exposed situation where the subfloor ventilation is more than 7000 mm² per m² of floor area.

6.0.3 Hot-dip galvanising can be used for connections to treated piles that are more than 600 mm from the ground in a sheltered situation where the subfloor ventilation is less than 7000 mm² per m² of floor area.

7.0 FURTHER READING

Ministry of Business, Innovation and Employment Building and Housing website

New Zealand Building Code Handbook

Compliance documents:

- B1/AS1 *Structure*
- B2/AS1 *Durability*

Standards New Zealand

NZS 3109:1997 *Concrete construction*

NZS 3604:2011 *Timber-framed buildings*

NZS 3605:2001 *Timber piles and poles for use in building*

NZS 3640:2003 *Chemical preservation of round and sawn timber.*

BRANZ publications

House Building Guide (3rd edition)

Bulletin 353 *Ground clearances*

Bulletin 459 *Timber pole house construction*

Bulletin 526 *Specifying timber*

Bulletin 538 *Timber treatment*

THE CORE PURPOSE OF BRANZ IS TO IMPROVE PEOPLE'S LIVES THROUGH OUR RESEARCH AND OUR DRIVE TO INFORM, EDUCATE AND MOTIVATE THOSE WHO SHAPE THE BUILT ENVIRONMENT.

BRANZ ADVISORY HELP LINES

FOR THE BUILDING INDUSTRY

0800 80 80 85

FOR THE HOME OWNER AND PUBLIC ENQUIRIES

0900 5 90 90

Calls cost \$1.99 per minute plus GST. Children please ask your parents first.

HEAD OFFICE AND RESEARCH STATION

Moonshine Road, Judgeford

Postal Address – Private Bag 50 908, Porirua 5240, New Zealand

Telephone – (04) 237 1170, Fax – (04) 237 1171

www.branz.co.nz

Standards referred to in this publication can be purchased from Standards New Zealand by phone 0800 782 632 or by visiting the website: www.standards.co.nz.

Please note, BRANZ books or bulletins mentioned in this publication may be withdrawn at any time. For more information and an up-to-date list, visit BRANZ Shop online: www.branz.co.nz or phone BRANZ 0800 80 80 85, press 2.

Disclaimer: The information contained within this publication is of a general nature only. BRANZ does not accept any responsibility or liability for any direct, indirect, incidental, consequential, special, exemplary or punitive damage, or for any loss of profit, income or any intangible losses, or any claims, costs, expenses, or damage, whether in contract, tort (including negligence), equality or otherwise, arising directly or indirectly from or connected with your use of this publication, or your reliance on information contained in this publication.

ISSN 1170-8395

Copyright © BRANZ 2013. No part of this publication may be photocopied or otherwise reproduced without the prior permission in writing from BRANZ.